



Most Widely Accepted and Trusted

ICC-ES Evaluation Report

ESR-4121

Issued 04/2019

ICC-ES | (800) 423-6587 | (562) 699-0543 | www.icc-es.org

This report is subject to renewal 04/2020.

**DIVISION: 31 00 00—EARTHWORK
SECTION: 31 63 00—BORED PILES**

REPORT HOLDER:

STABIL-LOC SYSTEMS, LLC

EVALUATION SUBJECT:

STABIL-LOC® FOUNDATION PIERING SYSTEM



“2014 Recipient of Prestigious Western States Seismic Policy Council (WSSPC) Award in Excellence”



ICC-ES Evaluation Reports are not to be construed as representing aesthetics or any other attributes not specifically addressed, nor are they to be construed as an endorsement of the subject of the report or a recommendation for its use. There is no warranty by ICC Evaluation Service, LLC, express or implied, as to any finding or other matter in this report, or as to any product covered by the report.



ICC-ES Evaluation Report

ESR-4121

Issued April 2019

This report is subject to renewal April 2020.

www.icc-es.org | (800) 423-6587 | (562) 699-0543

A Subsidiary of the International Code Council®

DIVISION: 31 00 00—EARTHWORK
Section: 31 63 00—Bored Piles

REPORT HOLDER:

STABIL-LOC SYSTEMS, LLC

EVALUATION SUBJECT:

STABIL-LOC® FOUNDATION PIERING SYSTEM

1.0 EVALUATION SCOPE

Compliance with the following codes:

- 2018, 2015 and 2012 *International Building Code (IBC)*
- 2018, 2015 and 2012 *International Residential Code (IRC)*

Property evaluated:

Structural

2.0 USES

Stabil-Loc® Foundation Piering System is designed to resist axial compressive loads from existing supported structures to supporting soil stratum.

When the piercing system is installed under the IRC, an engineered design is required in accordance with IRC Section R301.1.3.

3.0 DESCRIPTION

3.1 General:

The Stabil-Loc® Foundation Piering System consists of hydraulically driven steel pier segments connected to an adjustable head assembly that is in contact and connected with the load-bearing foundation of a structure, at a point which is concentrically loaded.

3.2 System Components:

3.2.1 Piering System Segments: The piercing system segments consist of outer pier segments and inner pier segments. The outer pier segments are 2⁷/₈-inch-outside-diameter (73 mm) pipe having a nominal shaft thickness of 0.217 inch (5.5 mm), and come in 12-inch lengths (305 mm). The inner pier segment is 2³/₈-inch-outside-diameter (60 mm) pipe having a nominal shaft thickness of 0.188 inch (4.8 mm), and come in 12-inch lengths (305 mm). The outer pier segments are connected together by inserting the 12-inch-long (305 mm) inner pier segments so that approximately 6 inches of the inner pier segment extends out of one end of the outer pier segment. During installation, the subsequent outer pier segments slide over

the inner pier segments of the previous outer pier segment. Figure 1 illustrates a typical piercing system used in conjunction with an adjustable head assembly. The starter assembly is composed of an outer pier segment with a factory-welded 3.25-inch-diameter-by-⁵/₁₆-inch-thick (82.6 by 7.9 mm) steel plate and a 6-inch-long (152 mm) inner pier segment. The starter assembly is jobsite-installed and is the bottom segment of the pier system. The piercing system components are available in bare steel.

3.2.2 Foundation Support Adjustable Head Assembly:

The foundation support adjustable head assembly is used to support existing concrete foundations supporting axial compressive loads. The adjustable head assembly is composed of a head plate, shim block and bearing plate. The head plate is composed of 3.5-inch-outside-diameter (89 mm) steel pipe having a nominal wall thickness of 0.188-inch (4.8 mm) and is 8.5 inches (216 mm) long with factory-welded steel support plate and gusset plates. The steel support plate is ³/₈-inch thick (10 mm) and the gusset steel plates are ⁵/₁₆-inch thick (8 mm). The shim block is composed of steel pipes, all-thread rod, heavy hex nuts and steel plate. The steel pipes are HSS2.875x0.217 (73 x 5.5 mm), HSS2.375x0.188 (60 x 4.8 mm) and HSS1.90x0.145 (48 x 3.7 mm) and are 6 inches (152 mm) long. The all-thread rod is 1½-inch (38 mm) by 8-inch-long (203 mm) steel rod. A heavy hex nut is factory-welded to the steel pipes and the other hex nut is used to engage with the bearing plate. A ¼-inch-thick (6 mm) steel plate is factory welded to the steel pipes. The bearing plate is composed of a steel angle L6x4x³/₈ (152 x 102 x 10 mm) and HSS2.875x0.217 (73 x 5.5 mm) steel pipe ¾-inch-long (19 mm) section that is factory-welded to the angle. The bearing plate also includes two ½-inch (12.7 mm) predrilled holes used for anchor bolt attachment. The adjustable head assembly components are available in bare steel. See Figure 1 showing an adjustable head assembly without top plate. When installed, the adjustable head assembly must include end support steel pipes and optional top plate as shown in Figure 2 of this report. The end supports are composed of two (2) HSS2.375x0.188 (60 x 4.8 mm) steel pipe cut to required length to bear between bearing plate and head plate. An optional top steel plate measuring 10-inch-by-18-inch-by-½-inch-thick (254 x 457 x 12.7 mm) may be placed between the bearing plate and the concrete foundation.

3.3 Material Specifications:

3.3.1 Pipe Segments: The pier segments are carbon steel round tube conforming to ASTM A500, Grade B, which have minimum yield strength of 46,000 psi (317 MPa) and a minimum tensile strength of 58,000 psi (400 MPa).

3.3.2 Foundation Adjustable Head Assembly:

3.3.2.1 Plates and Angles: The steel plates and steel angle used to fabricate the adjustable head assembly conform to ASTM A36, which have a minimum yield strength of 36,000 psi (248 MPa) and a minimum tensile strength of 58,000 psi (400 MPa).

3.3.2.2 Sleeves: The carbon steel round tube used in the adjustable head assembly as a sleeve conforms to ASTM A500, Grade B, which have minimum yield strength of 46,000 psi (317 MPa) and a minimum tensile strength of 58,000 psi (400 MPa).

3.3.2.3 Threaded Rods and Nuts: The threaded rods conform to ASTM A193 Grade B7. The heavy hex nuts conform to ASTM A194 Grade 2H.

4.0 DESIGN AND INSTALLATION

4.1 Design:

4.1.1 General: Engineering calculations (analysis and design) and drawings, prepared by a registered design professional, must be submitted to and be subjected to the approval of the code official for each project, and must be based on accepted engineering principles, as described in IBC Section 1604.4, and must conform to IBC Section 1810. The design method for the steel components is Allowable Strength Design (ASD), described in IBC Section 1602 and AISC 360 Section B3.4. The engineering analysis must address foundation piercing system performance related to structural and geotechnical requirements.

The structural analysis must consider all applicable internal forces (shears, bending moments and torsional moments, if applicable) due to applied loads, structural eccentricity and maximum span(s) between push pier systems. The minimum embedment depth for various loading conditions must be included based on the most stringent requirements of the following: engineering analysis, allowable capacities noted in this report, site-specific geotechnical investigation report, and site-specific load tests, if applicable. A soil investigation report in accordance with this section (Section 4.1.1) must be submitted for each project. The soil interaction capacity between the pile and the soil including the required safety factor and the soil effects of the foundation piercing system installation must be determined in accordance with the applicable code by a registered design professional. The maximum installation force and working capacity of the foundation piercing system must be determined in accordance with Stabil-Loc installation instructions and as recommended by a registered design professional. The allowable strengths (allowable capacities) of the steel components of the Stabil-Loc® Foundation Piercing System are described in Table 1 (for adjustable head assembly and pier segments).

A written report of the geotechnical investigation must be submitted to the code official as part of the required submittal documents, prescribed in IBC Section 107, at the time of the permit application. The geotechnical report must include, but not be limited to, all of the following information:

- A plot showing the location of the soil investigation.
- A complete record of the soil boring and penetration test logs and soil samples.
- A record of soil profile.
- Information on ground-water table, frost depth and corrosion related parameters, as described in Section 5.5 of this report.

- Soil properties, including those affecting the design such as support conditions of the piles.
- Soil design parameters; soil deformation parameters; and relative pile support conditions as defined in IBC Section 1810.2.1.
- Confirmation of the suitability of Stabil-Loc® Foundation Piercing System for the specific project.
- Recommendations for design criteria, including but not be limited to: mitigations of effects of differential settlement and varying soil strength; and effects of adjacent loads.
- Recommended center-to-center spacing of pile foundations, if different from Section 5.13 of this report, the manufacturer's published installation instructions and accepted engineering principles and reduction of allowable loads due to the group action, if necessary.
- Field inspection and reporting procedures (to include procedures for verification of the installed bearing capacity when required).
- Load test requirements.
- Any questionable soil characteristics and special design provisions, as necessary.
- Expected total and differential settlement.
- The axial compression load soil capacities for allowable capacities that cannot be determined from this evaluation report.
- Minimum pile depth, if any, based on local geologic hazards such as frost, expansive soils, or other condition.

4.1.2 Adjustable Head Assembly Capacity: The concrete foundation must be designed and justified to the satisfaction of the code official with due consideration to the eccentricity of applied loads, including reactions provided by the adjustable head assembly, acting on the concrete foundation. Only localized limit states of supporting concrete foundation, including bearing and punching shear, have been evaluated in this evaluation report. Other limit states are outside the scope of this evaluation report and must be determined by the registered design professional. The effects of reduced lateral sliding resistance due to uplift from wind or seismic loads must be considered for each project. Reference Table 1 for the allowable adjustable head assembly capacity ratings.

4.1.3 Pier Segment Capacity: Table 2 describes the nominal and allowable (ASD) axial compression loads of the pier segments which are based on a 50-year corrosion effect in accordance with Section 3.9 of the ICC-ES Acceptance Criteria for Helical Pile Systems and Devices (AC358). The top of pier segments must be braced as prescribed in IBC Section 1810.2.2, and the supported foundation structures such as concrete footings are assumed to be adequately braced such that the supported foundation structures provide lateral stability for the pile systems. In accordance with IBC Section 1810.2.1, any soil other than fluid soil must be deemed to afford sufficient lateral support to prevent buckling of the systems that are braced, and the unbraced length is defined as the length of piles that is standing in air, water or in fluid soils plus additional 5 feet (1524 mm) when embedded into firm soil or additional 10 feet (3048 mm) when embedded into soft soil. Firm soils shall be defined as any soil with a Standard Penetration Test blow count of five or greater. Soft soil shall be defined as any soil with a Standard Penetration Test

blow count greater than zero and less than five. Fluid soils shall be defined as any soil with a Standard Penetration Test blow count of zero [weight of hammer (WOH) or weight of rods (WOR)]. Standard Penetration Test blow count shall be determined in accordance with ASTM D1586.

The elastic shortening of the pier segments will be controlled by the strength and section properties of the pier segments. For loads up to and including the allowable load limits found in this report, the elastic shortening of pier segment can be estimated as:

$$\Delta_{\text{shaft}} = P L / (A E)$$

where:

Δ_{shaft} = Length change of pier segments resulting from elastic shortening, in (mm).

P = applied axial load, lbf (N).

L = effective length of the pier segment, in. (mm).

A = cross-sectional area of the pier segment, which must account for corrosion loss and determined by registered design professional, in.² (mm²).

E = Young's modulus of the shaft, ksi (MPa).

4.2 Installation:

The Stabil-Loc[®] Foundation Piering System must be installed by Stabil-Loc[®] Inc. certified and trained installers. The Stabil-Loc[®] Foundation Piering System must be installed in accordance with this section (Section 4.2) and the manufacturer's installation instructions.

4.2.1 Hydraulically Driven Steel Pier Segments and Adjustable Head Assembly Installation:

1. An area must be excavated immediately adjacent to and 28 inches (711 mm) below the building foundation to expose the bottom of the footing, bottom of grade beam, stem wall or column to a width as indicated in the manufacturer's installation instructions.
2. The bottom face of the foundation must, to the extent possible, be smooth for the mounting of the bearing plate. The surface in contact with the bearing plate must be free of all dirt, debris and loose concrete so as to provide firm bearing surface. Reference Figure 1 for proper bearing placement.
3. The pier segment starter assembly is the first segment installed. It must be installed directly under the center of the stem or basement wall, regardless of the position of the wall on top of the spread footing. Additional inner and outer pier segments must be installed until the desired depth is achieved. Advancement of the pier segments will continue until one of the following occurs; the structure begins to experience uplift, the desired hydraulic pressure is achieved or as determined by the foundation investigation report. The load applied during installation of the pier segments should not be more than as shown in Table 1 of this report. Pier segments must be installed vertical and be plumb.
4. All pier segments must be installed individually utilizing the maximum resistance of the structure as a reaction force to install each pier segment. The location of the pier segment system must be determined by a registered design professional. Lifting of the structure must be verified by the registered design professional to ensure that the foundation and/or superstructure are not overstressed.
5. After termination of the pier segments, the excess pier segment section must be cut off squarely at a sufficient

height to allow for foundation lifting. The end of the pier segments must be fully bearing on the head plate. The head plate must be used to support the hydraulic rams used to lift the structure. The bearing plate must be installed leveled and be fully bearing on the concrete foundation. The location of the bearing plate must comply with Table 1 of this report. The shim block is installed to complete the installation. Two ³/₈-inch (9.5 mm) steel bolts with matching nuts are used to connect the shim block to the head plate. A HSS2.375x0.188 steel pipe segment must be cut to fit and installed on both sides of the shimblock. An optional top plate may be installed between the bearing plate and underside of concrete foundation.

6. The excavation must be back-filled and the soil properly compacted. Excess soil must be removed.

4.3 Special Inspection:

Special inspection in accordance with IBC Section 1705.7, is required for installation of the Stabil-Loc[®] Foundation Piering System. The special inspector must verify the following:

1. Verification of manufacturer product model numbers (see Section 3.0).
2. Types, configurations and identifications of hydraulically driven steel pier segment and adjustable head assembly as specified in this report and the construction documents.
3. Installation procedures, anticipated and actual piling depth.
4. Tip elevations, the installation pressure and final depth of the driven foundation system.
5. Inclination and position/location of hydraulically driven steel pier segments.
6. Compliance of the installation with the approved construction documents and this evaluation report.

5.0 CONDITIONS OF USE

The Stabil-Loc[®] Foundation Piering System described in this report comply with, or is a suitable alternatives to what is specified in, those codes indicated in Section 1.0 of this report, subject to the following conditions:

- 5.1 The pier segment foundation system is manufactured, identified and installed in accordance with this report, the approved construction documents and the manufacturer's published installation instructions. In the event of a conflict between this report, the approved construction documents and the manufacturer's published installation instructions, the most restrictive governs.
- 5.2 Pier Segment Foundation systems have been evaluated to support structures in Seismic Design Categories (SDCs) A, B and C. Use of the systems to support structures assigned to SDC D, E or F, or which are located in Site Class E or F, are outside the scope of this report and are subject to the approval of the building official, based upon submission of a design in accordance with the code by a registered design professional.
- 5.3 Installation of the hydraulically driven pier segment systems must be limited to support of uncracked normal-weight concrete, as determined in accordance with the applicable code.
- 5.4 Adjustable head assembly must be used only to support structures that are laterally braced as defined in IBC Section 1810.2.2.

- 5.5 Use of the hydraulically driven pier segment systems in conditions that are indicative of a potential pile corrosion situation as defined by soil resistivity of less than 1000 ohm-cm, a pH of less than 5.5, soils with high organic content, sulfate concentrations greater than 1000 ppm, landfills, or mine waste is beyond the scope of the evaluation report.
- 5.6 The adequacy of the concrete structures that are connected to Stabil-Loc adjustable head assembly must be verified by a registered design professional, in accordance with applicable code provisions, such as Chapter 13 of ACI 318-14 under the 2018 and 2015 IBC (Chapter 15 of ACI 318 under the 2012 IBC) and Chapter 18 of IBC, and subject to the approval of the code official.
- 5.7 The hydraulically driven pier segment must be installed vertically into the ground with a maximum allowable angle of inclination of 1 degree.
- 5.8 Special inspection is provided in accordance with Section 4.3 of this report.
- 5.9 Engineering calculations and drawings, in accordance with recognized engineering principles and design parameters as described in IBC Section 1604.4, and in compliance with Section 4.1 of this report, are prepared by a registered design professional and approved by the building official.
- 5.10 A soils investigation for each project site must be provided to the building official for approval in accordance with Section 4.1.1 of this report.
- 5.11 Evaluation of compliance with IBC Section 1810.3.11.1 for buildings assigned to Seismic Design Category (SDC) C, and with IBC Section 1810.3.6 for all buildings, is outside of the scope of this evaluation report. Such compliance must be addressed by a registered design professional for each site, and is subject to approval by the code official.
- 5.12 Settlement of the hydraulically driven pier segment system is outside the scope of this evaluation report and must be determined by a registered design professional as required in IBC Section 1810.2.3.
- 5.13 In order to avoid group efficiency effects, an analysis prepared by a registered design professional must be submitted where the center-to-center spacing of axially load piles is less than three times the pile diameter.
- 5.14 The interaction between the hydraulically driven pile system and the soil is outside the scope of this report.
- 5.15 The Stabil-Loc® Foundation Piering System are manufactured at the Stabil-Loc manufacturing facility in Springdale, Arkansas, under a quality control program with inspections by ICC-ES.
- ## 6.0 EVIDENCE SUBMITTED
- Head Assembly axial compression load tests.
 - Pier segment axial compression load tests.
 - Engineering calculations of head assembly
 - Quality control documentation and installation instructions.
- ## 7.0 IDENTIFICATION
- 7.1 The Stabil-Loc® Foundation Piering System components are identified by a tag or label bearing the name and address of Stabil-Loc Systems, LLC, the catalog number, the product description, and the evaluation report number (ESR-4121).
- 7.2 The report holder's contact information is the following:
- STABIL-LOC SYSTEMS, LLC**
444 OLD WIRE ROAD
SPRINGDALE, ARKANSAS 72764
(479) 320-7117
www.stabil-loc.com

TABLE 1—FOUNDATION STRENGTH RATINGS OF ADJUSTABLE HEAD ASSEMBLY^{1,2,3,4}

ADJUSTABLE HEAD ASSEMBLY TYPE	CONCRETE DIMENSIONS		ALLOWABLE COMPRESSION AXIAL LOAD CAPACITY ^{12,13} (kips)
	Concrete Cover ⁷ (inches)	Edge Distance ⁸ (inches)	
ADJUSTABLE HEAD ASSEMBLY WITHOUT TOP PLATE ⁵	17	17	93.0
	8	8 ⁹	32.6
	12	12 ^{9,10}	55.5
ADJUSTABLE HEAD ASSEMBLY WITH TOP PLATE ⁶	14	14	93.0
	8	8 ⁹	43.1
	12	12 ^{9,11}	72.0

For **SI**: 1 inch = 25.4 mm, 1 kip (1000 lbf) = 4.48 kN.

¹Load capacity is based on pier segments installed fully braced and sidesway braced per IBC Section 1810.2.2.

²The inner and outer pier segment must be installed bearing on support head plate.

³Support adjustable head assembly must be concentrically loaded. Bearing plate must be installed leveled and be fully engaged with bottom of concrete foundation.

⁴Only localized limit states such as mechanical strength of steel components, concrete punching shear, and concrete bearing have been evaluated. Other applicable limit states must be verified by registered design professional.

⁵Adjustable head assembly without top plate is as shown in Figure 2 of this report without the additional 10-inch by 18-inch steel plate.

⁶Adjustable head assembly with top plate is as shown in Figure 2 of this report.

⁷Concrete cover is defined as the minimum distance from the top of the bearing plate or top plate, as applicable, to the top of the concrete foundation.

⁸Edge distance is defined as the minimum distance from the edge of the bearing plate or top plate, as applicable, to the edge of the concrete foundation, unless noted otherwise.

⁹Concrete width must be minimum 24 inches.

¹⁰The minimum edge distance between the 6-inch bearing plate dimension to the edge of the concrete must be 9 inches.

¹¹The minimum edge distance between the 10-inch top plate dimension to the edge of the concrete must be 9 inches.

¹²The tabulated load values are based on installation with normal-weight concrete having a minimum compressive strength of 3000 psi (17.23 MPa).

¹³Allowable axial compression capacity is based on steel losing 0.036-inch as indicated in Section 3.9 of AC358 for a 50-year service life.

TABLE 2—NOMINAL AND ALLOWABLE (ASD) COMPRESSION CAPACITY OF PIER SEGMENTS (kips)

Fully Braced ($L_u=0$) ¹	Axial Compression Load ^{2,3}
Nominal	211.1
ASD	105.5

For **SI**: 1 kip (1000 lbf)=4.48 kN.

¹ L_u = Total unbraced pile length per IBC Section 1810.2.1, including the length in air, water or in fluid soils, and the embedment length into firm or soft soil (non-fluid soil). KL_u = total effective unbraced length of the pile, where $kL_u=0$ represent a fully braced condition in that the total pile length is fully embedded into firm or soft soil and the supported structure is braced in accordance with IBC Section 1810.2.2.

²Nominal loads are based on ultimate test load. ASD is based on safety factor of two. Tabulated load values are based on steel losing 0.036-inch as indicated in Section 3.9 of AC358 for a 50-year service life.

³ Pier segments (inner and outer) must be installed in accordance with Section 4.2 of this report.

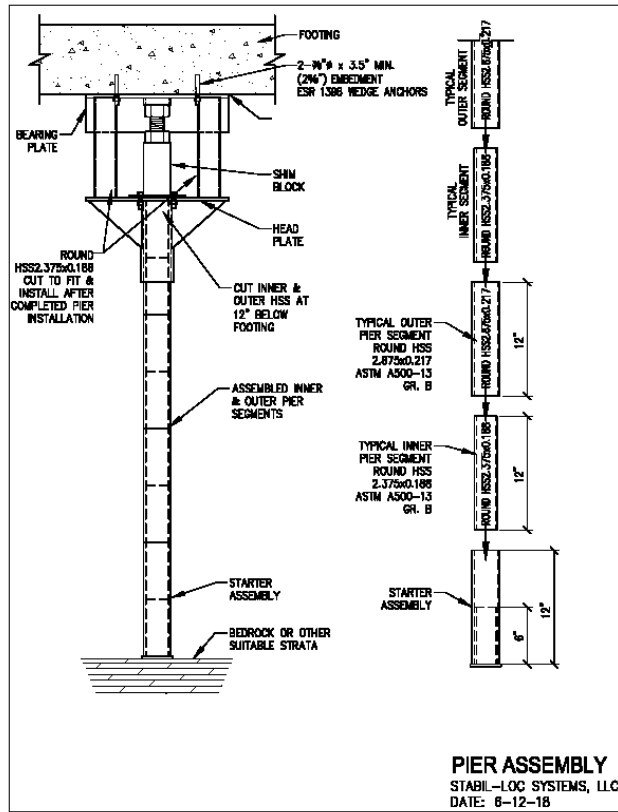

FIGURE 1—STABIL-LOC® FOUNDATION PIERING SYSTEM

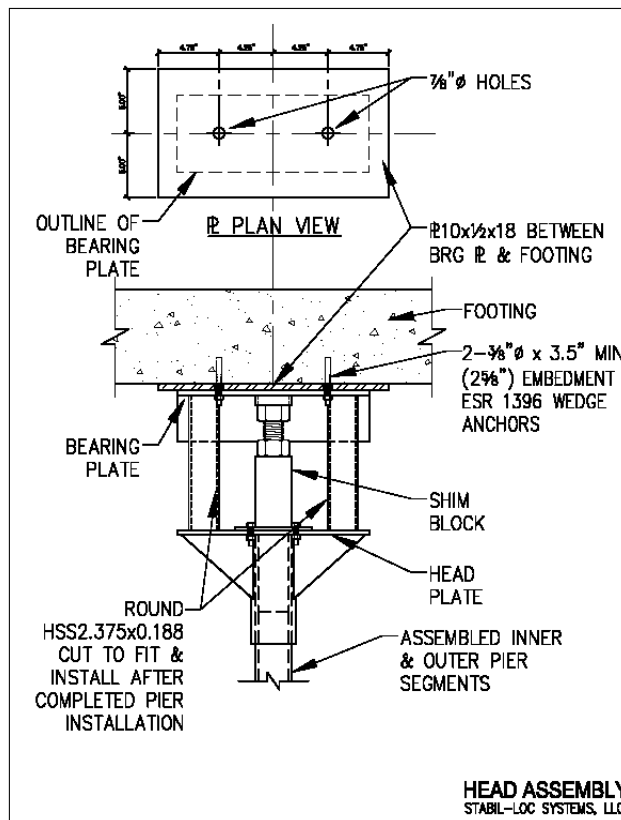

FIGURE 2—STABIL-LOC® FOUNDATION PIERING SYSTEM ADJUSTABLE HEAD ASSEMBLY